

Users Guide to the Coronado Personal Solar Telescope

From the Arkansas State Library's
Circulating Solar Science Kit



Helpful Notes for the Beginning to Intermediate User

Darcy Howard
and
Carl Freyaldenhoven
Central Arkansas Astronomical Society
2023

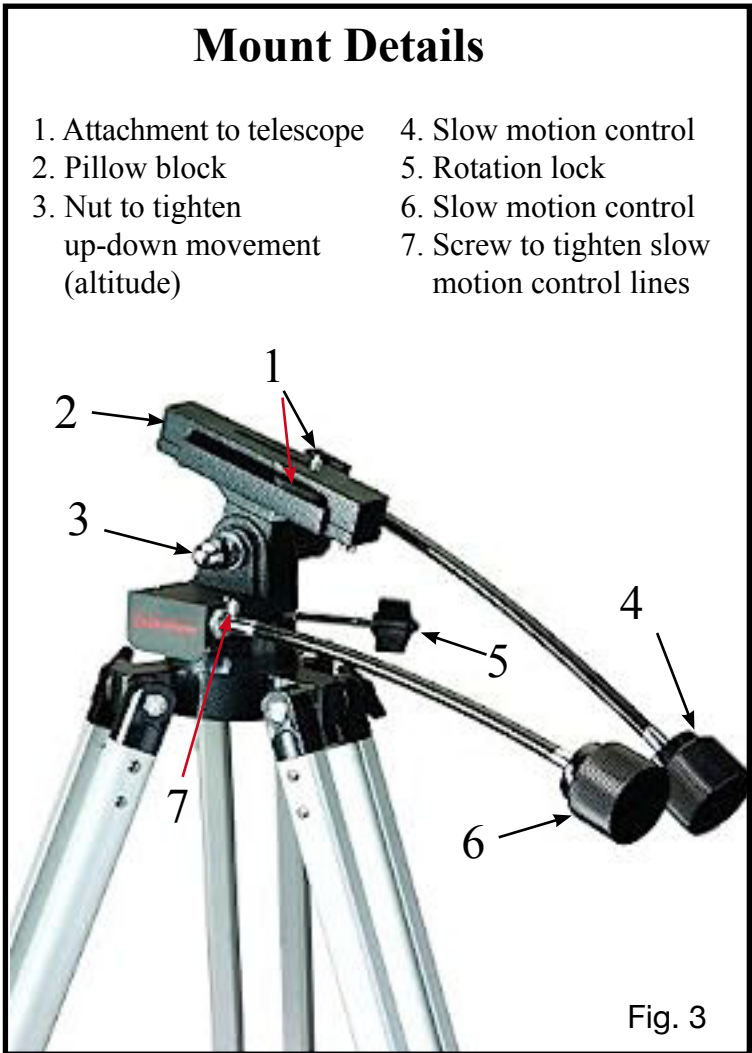
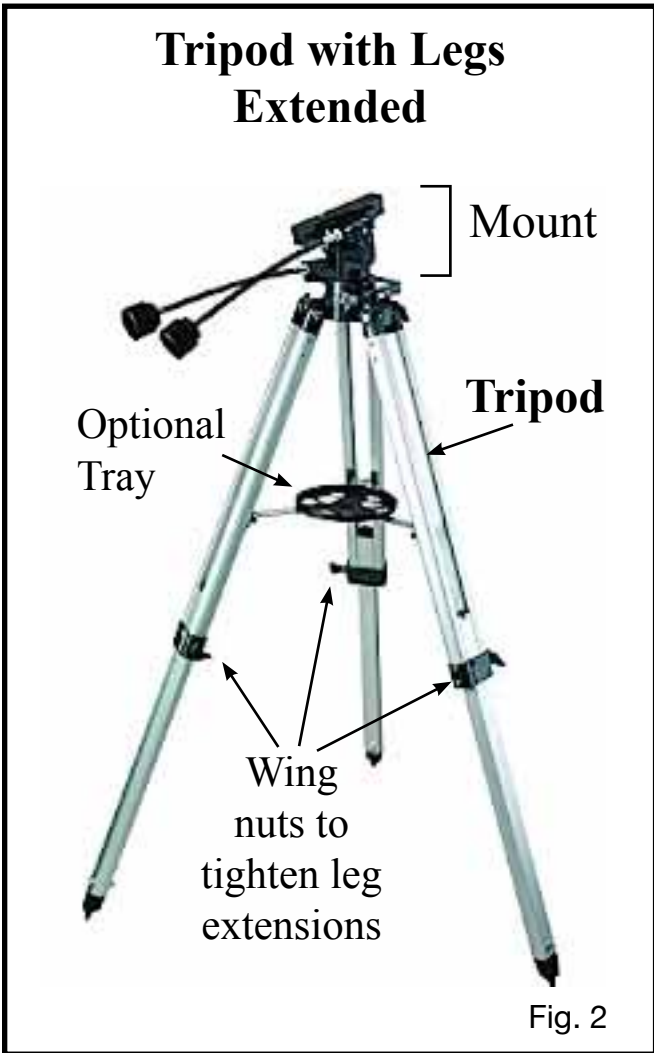
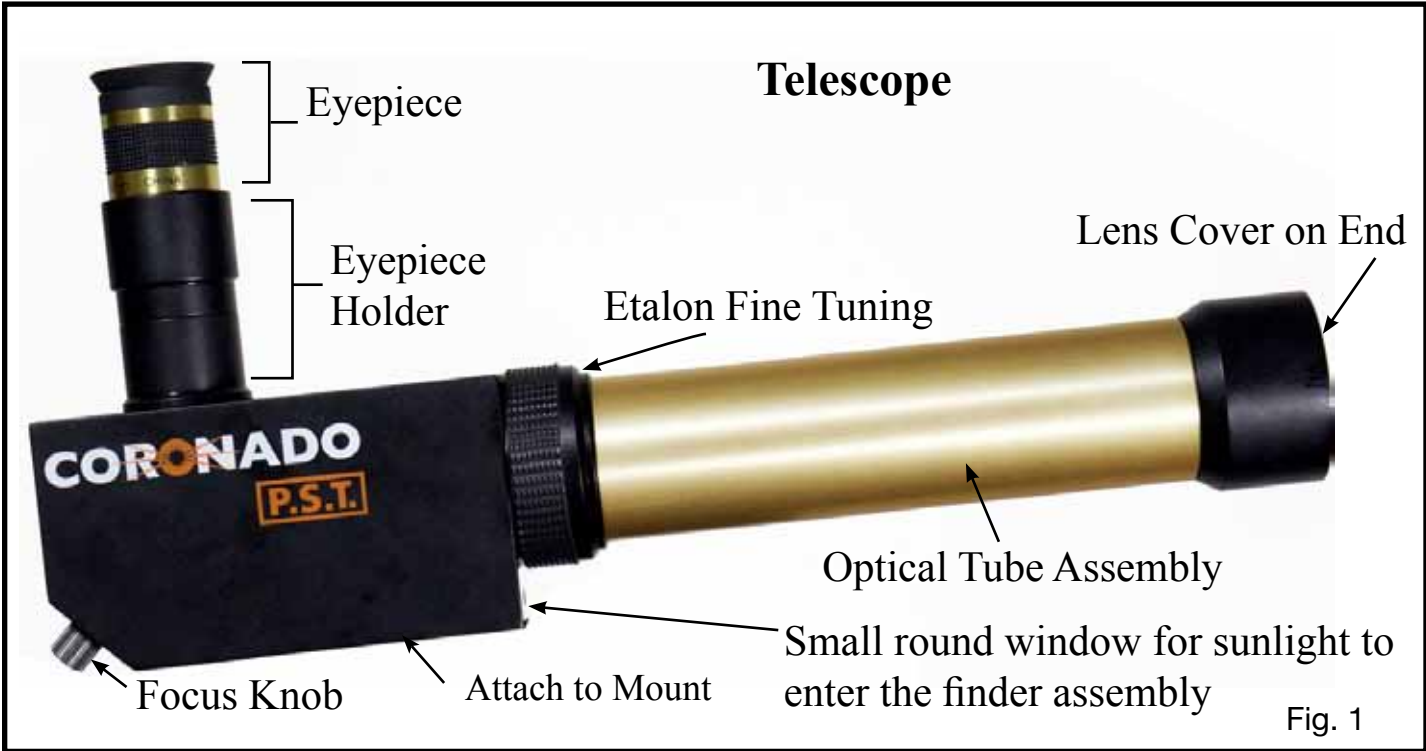

Hooray! You are fortunate to be using a specialty Hydrogen-alpha solar telescope for observing the sun!

If you are a beginning user, here are tips that will help you get started on your solar observing journey.

This H-alpha solar telescope is different from other telescopes you might have used before. This telescope has one purpose only - to look at the sun in a narrow bandwidth of red light.

That said, we have to repeat what we hope you already know: the sun is dangerously bright and looking at the sun without proper filters, especially through a magnified view, will cause serious eye injury. Don't try to disassemble the telescope, doing so may compromise your safety.

The unit comes as a separate telescope with a tripod and mount. These two parts have been assembled for you already. There are some smaller parts in the kit you will need to add on and maintain. They come separately for ease of storage.



SET UP

Start with the tripod. Loosen the three screw knobs in the center of the tripod legs so you can extend the legs to a comfortable height. Tighten the screw knobs to secure the legs in place.

Tip: It is safer for you and the equipment if you stand between two of the outstretched legs of the tripod instead of straddling one of them.

Fig. 4

Cable Attachment Pin



Locate the two silver colored cable attachment pins on the mount, they each have a flat side for the cable screw to tighten against. Connect a slow motion cable to one of these silver pins making sure the screw is meeting the flat side of the pin. Repeat for the second cable.

Note: These pins are easy to break off if the cable attachment screws are tightened too much.

Try using a dime to tighten the cable screws instead of a screwdriver. These pins are one end of a longer threaded screw that moves the telescope in small increments.

The travel of the controlling guide screws is 1-1/2 inches, so the guide will have to be brought back to center when it reaches the end of the threads. One of the control screws is plainly visible from the top of the mount. The other is visible from underneath. When the end of the threading has been reached, simply turn the cable in reverse to move the guide back to the center of the threads.

A long handled lock knob is included in the kit to lock the mount from rotating. You will need the mount to rotate when you are searching the sky so you really don't need the locking handle. The handle is included in the kit if you do need to use it.

If you have difficulty pointing the telescope upwards, it may be that the large nut that allows the mount to pivot upward was tightened too much. You will need a 3/4 inch wrench to loosen the nut so the tube can be tilted upward. Be careful not to loosen or tighten the nut too much.



The Attachment

This large screw knob is for attaching the telescope to the pillow block on the tripod mount

You Need to Know: The telescope housing is screwed onto a pillow block on the mount of the tripod with a single short screw. It is the same kind of screw attachment as a camera would be mounted to a tripod. When rotating the telescope left or right, you want to be sure you are turning the entire rotating head assembly and not inadvertently unscrewing the telescope from the mount.

After the above has been attended to:

Loosen the retaining screw on the eyepiece holder, remove the protective dust plug from the eyepiece holder, remove caps from the eyepiece and insert the eyepiece into the holder. The eyepiece is packaged separately in your kit. Gently yet snugly tighten the screw to hold the eyepiece in place. Store the plastic eyepiece stopper and lens caps where they are safe.

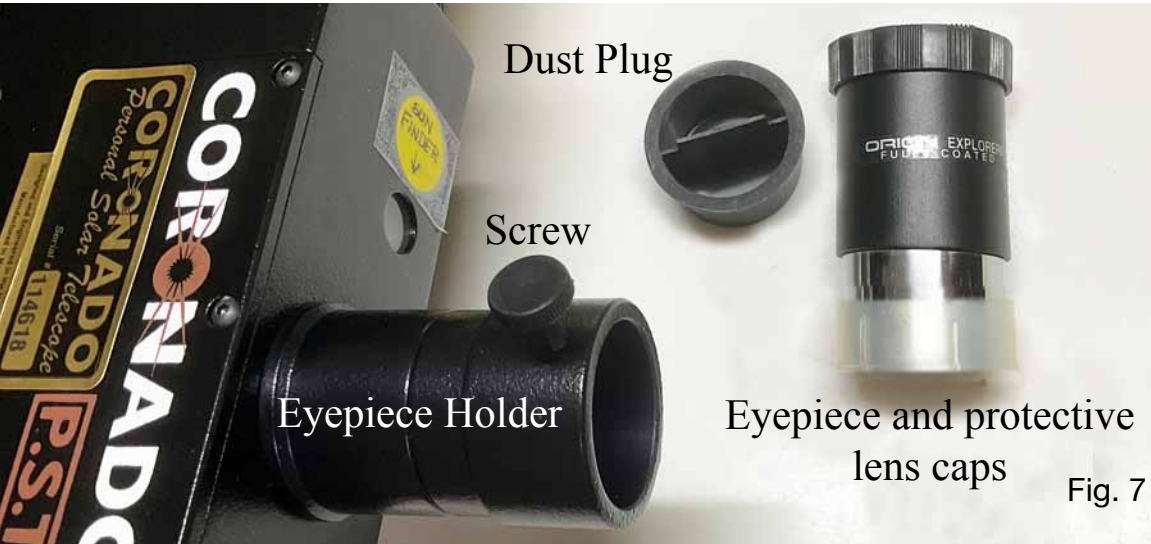

FINDING THE SUN

Remove the lens cap from the end of the gold optical tube and remember where you put it. Point the telescope toward the sun's general direction using your hands to move the gold tube up and down or left and right.



Look at the telescope's shadow on the ground. Align the telescope so the shadow of the telescope is as small as possible. The smallest shadow means you have the telescope aimed at the sun.

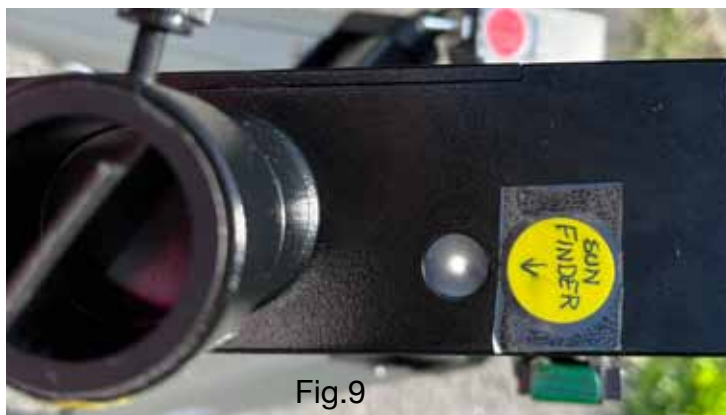

The sun finder, or “Sol Ranger,” is on top of the telescope near the eyepiece holder. If necessary raise, lower or rotate the telescope until a bright white dot appears in the window of the sunfinder. Use the slow motion cables to center the dot in the window. That dot is sunshine.

The white dot may not be in the exact center of the finder window when the sun is visible through the eyepiece. When you do locate the sun, check the viewfinder to see where it is actually located in the finder window.

Your eye may need a bit of training to look through the eyepiece. Put your eye close to the lens and look around inside the field of view. You might see the sun just at the edge of the field of view, or see a red glow, which means you are close to finding the sun.

If a bright red ball is in the field of view, congratulations on finding the sun! If it is not visible, use the two slow motion control knobs to look for a red glow and move toward the glow. Center the sun in the field of view. Patience and practice will reward you.

If you can't find the white dot in the finder, make sure a shadow is not blocking the finder's small round entry window on the bottom front of the black telescope housing.

If you see a white dot in the finder but can't see the sun in the eyepiece check that the lens cover has been removed.

FOCUSING

The red ball of the sun is unmistakable when you see it! The red glare around it is a clue you are getting close to it in the eyepiece. When you find the sun, focusing is the next step. The grooved silver focusing knob is on the back and lower part of the telescope housing (Fig. 1). Turn this knob as you are looking at the sun's disk to bring features into focus. Focusing on the edge of the sun will bring prominences into focus.

The fine focus, also called tuning, is achieved by rotating the black ring (Fig.1) at the base of the gold optical tube where it meets the housing. This tuning adjusts the heart of the Hydrogen-alpha solar telescope: a special filter called the etalon. The etalon is a precision made narrowband solar filter (read: expensive \$\$\$) which allows only the deep red color of the sun's chromosphere to be seen. The ring adjusting the etalon does not rotate more than 130 degrees, so do not use excessive force when turning it. It is generally used when sharp contrast can't be achieved using the silver focus knob.

WHAT YOU CAN SEE

The black spots on the sun are sunspots. The patchy white areas are plage. Filaments are dark string-like features on the sun's disk. Prominences are a wow factor of astounding jets or sprays from the edge of the sun with many different forms.

Because the Earth is rotating you will need to turn the slow motion cables to keep the sun in view.

HELPFUL TO HAVE

A sturdy step stool to sit, stand, or lean on while using the telescope is useful. The step stool is also a good hand-hold for youngsters so they won't reach for the eyepiece as a handle.

Since you are observing in the sun, a simple homemade cardboard sun-screen to shade your face is a creature comfort, easing glare on your eyes.



Fig.10



Fig. 11

CARE

When you are finished observing, replace the lens cap and safely store the eyepiece with its protective caps. Also put the plug back in place in the eyepiece holder. A caution on using the screw with the plastic dust plug - you don't have to tighten the screw so much that it makes a hole in the plastic plug.

Don't put your fingers on the glass eyepieces or the other lens at the front of the telescope (the objective lens.) These are optical quality glass components that must be cared for with respect.

The manufacturer recommends cleaning dust from the lens with a fine camel hair brush and then using a high quality lens cleaner and a soft (and CLEAN!) cloth.

TIP: Be mindful of your feet, it is easy to bump into the tripod legs. We have all done it.

Store the telescope in a climate controlled area. Humidity can damage some of the filters, making them become cloudy.

Care for the telescope as you would any high quality optical device.

RECOMMENDED READING

Sky & Telescope Observer's Guide to H-alpha Sun

<https://skyandtelescope.org/observing/guide-to-observing-the-sun-in-h-alpha092321050923/>

Sky & Telescope: Sunspots, Facula and Flares

<https://skyandtelescope.org/observing/observing-the-sun/>

Space.com

<https://www.space.com/sun-observing-safety-guide>

Don't forget your sunscreen and sun hat.

Clear skies!